

► Cam Unit - PCU - CS2.1-80-(00-55)

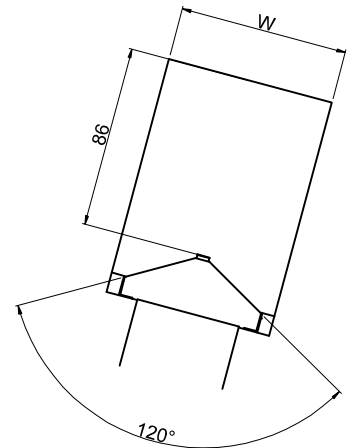

Z-View

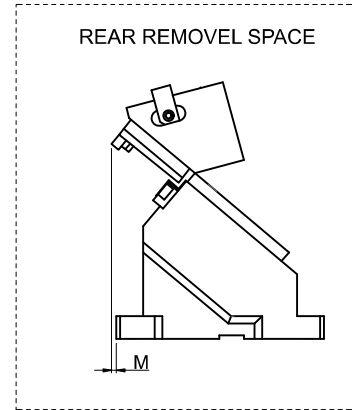
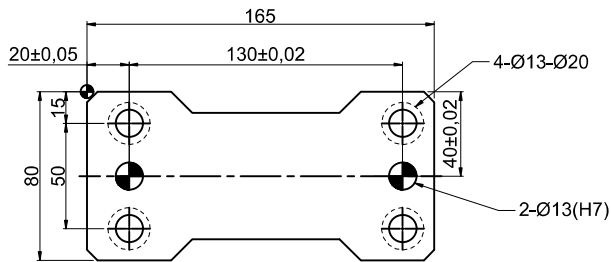
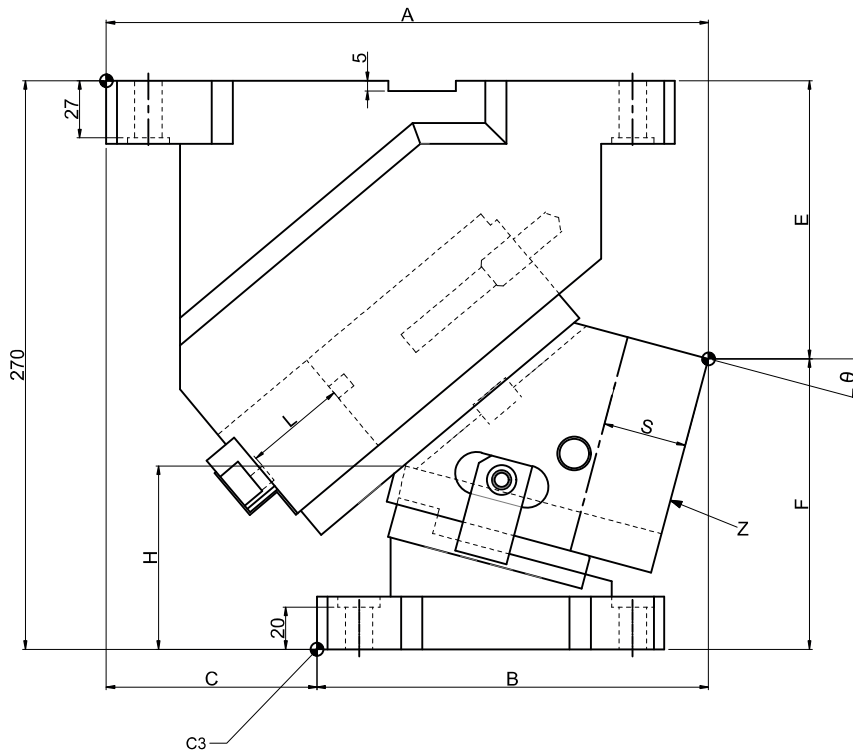
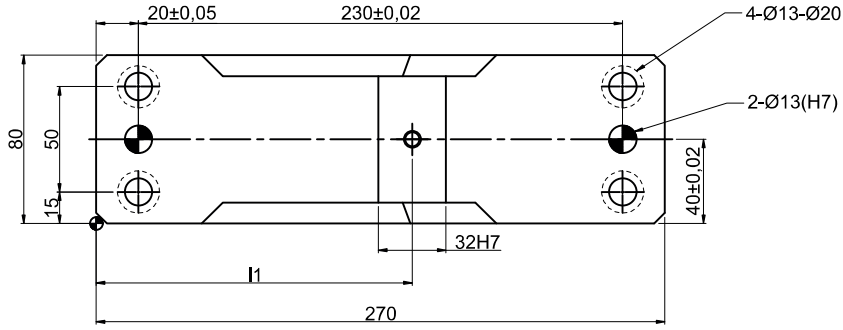
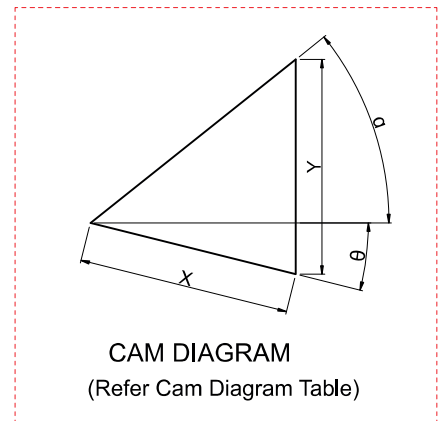

CAM DIAGRAM
(Refer Cam Diagram Table)

